

# **WORX**

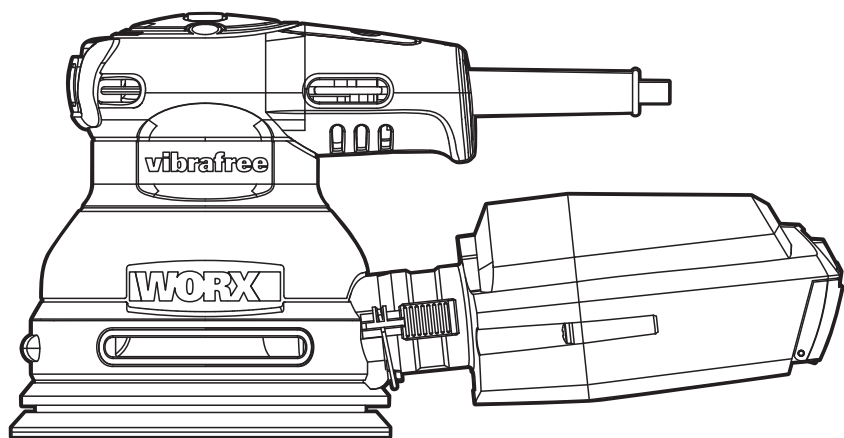

## **SAFETY AND OPERATING MANUAL**

**Random orbit sander**

**WX655**



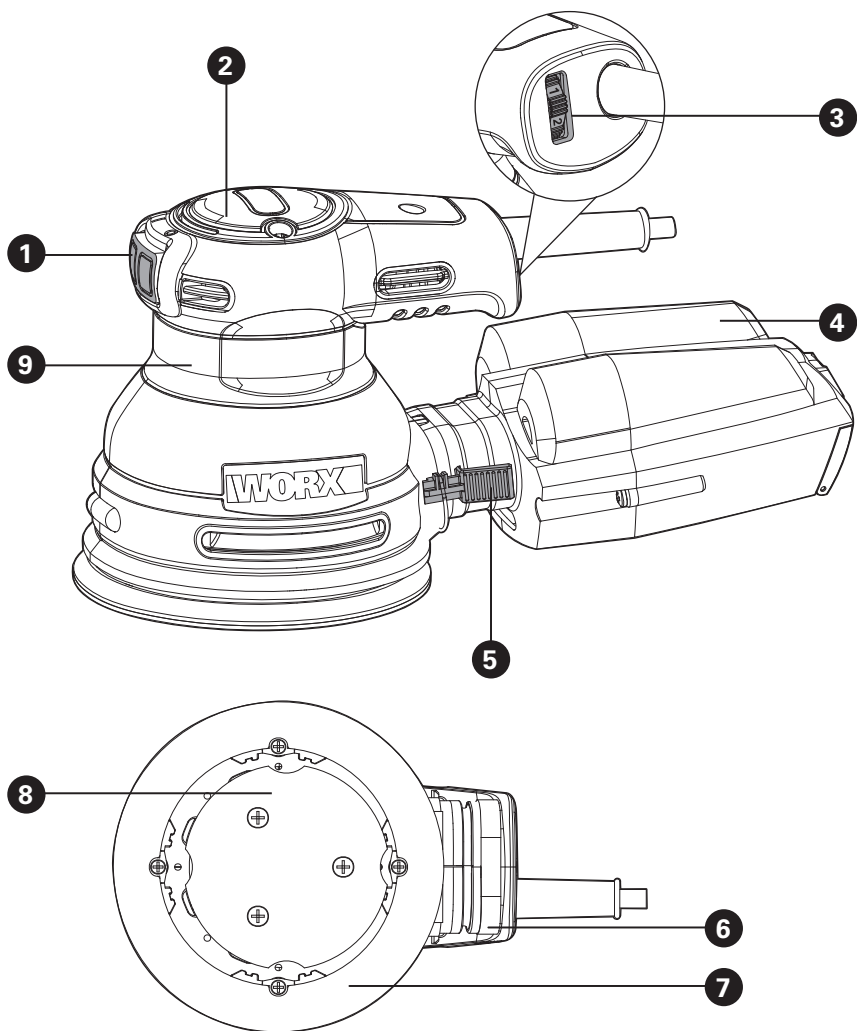

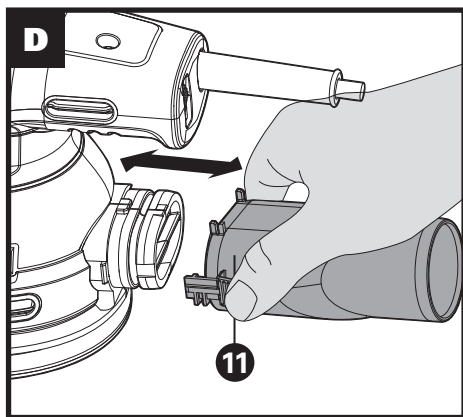
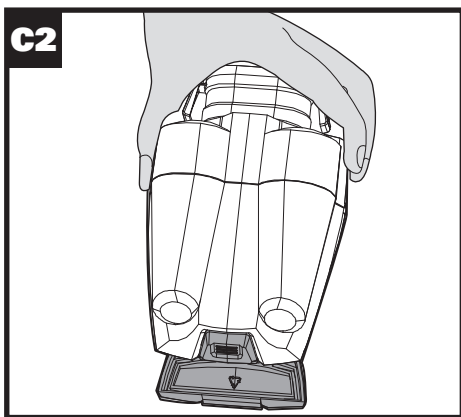
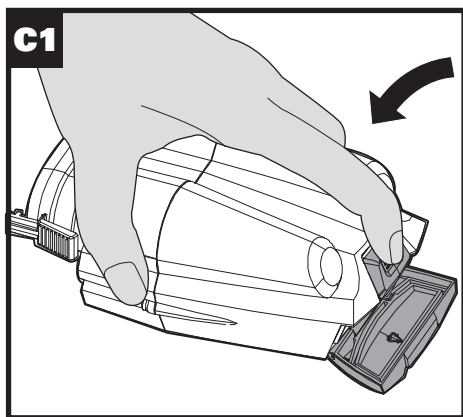
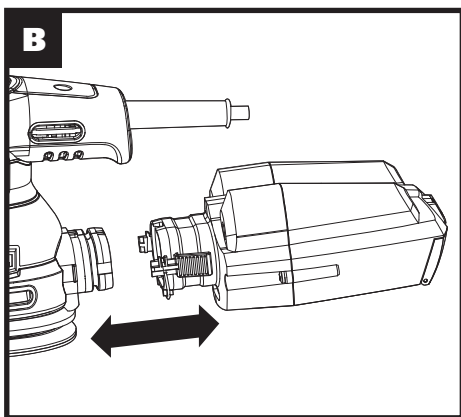
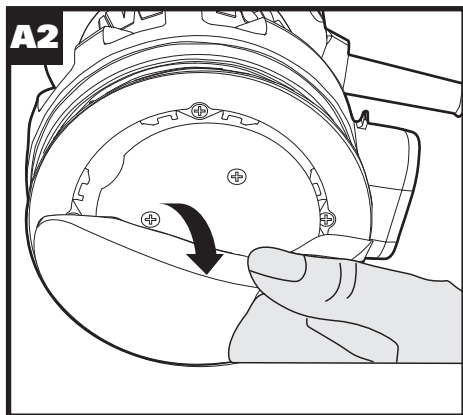
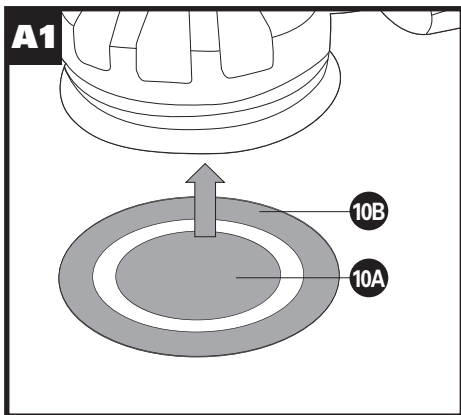

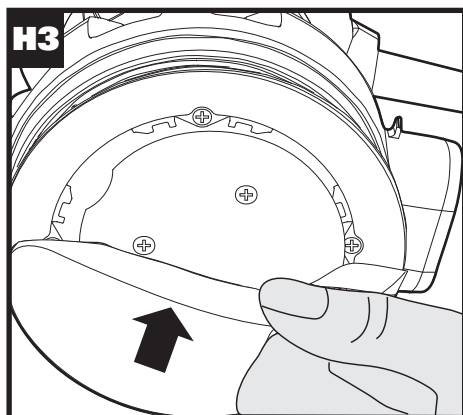
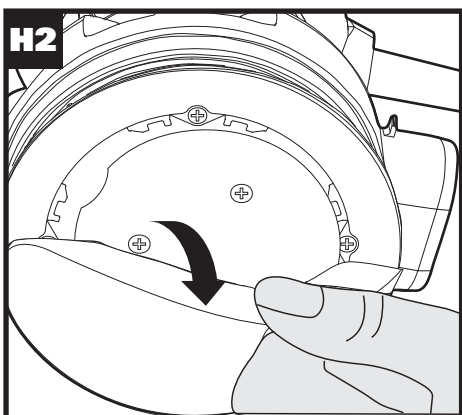
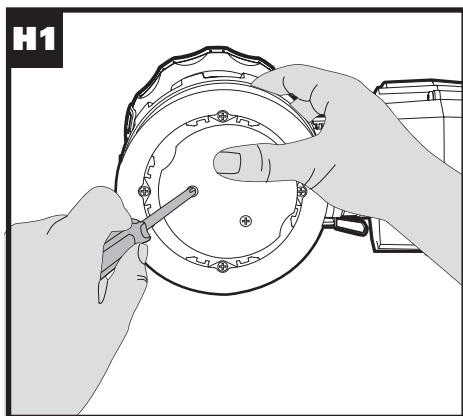
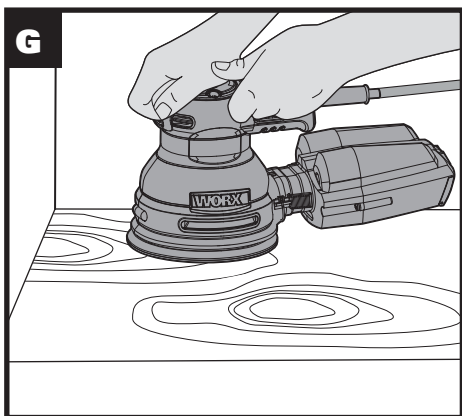
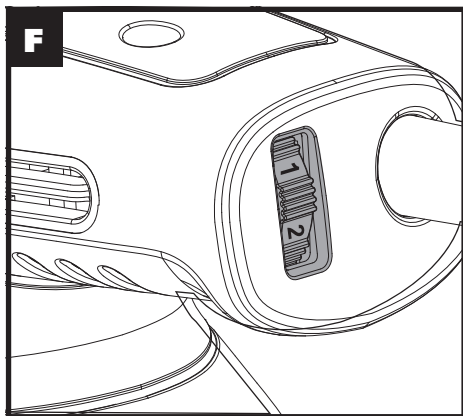
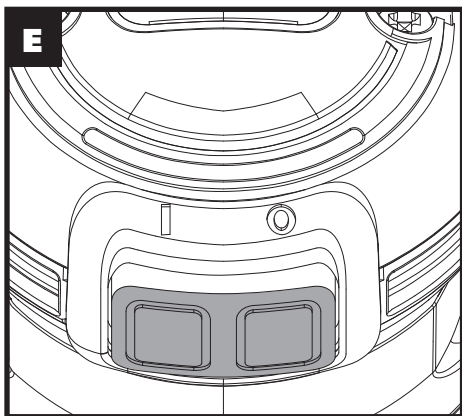

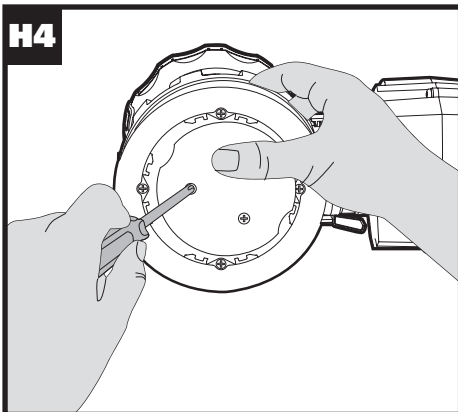

# GENERAL POWER TOOL SAFETY WARNINGS



**WARNING! Read all safety warnings and all instructions.** Failure to follow the warnings and instructions may result in electric shock, fire and/or serious injury.

**Save all warnings and instructions for future reference.**

The term "power tool" in the warnings refers to your mains-operated (corded) power tool or battery-operated (cordless) power tool.

## 1. WORK AREA SAFETY

- a) **Keep work area clean and well lit.** Cluttered or dark areas invite accidents.
- b) **Do not operate power tools in explosive atmospheres, such as in the presence of flammable liquids, gases or dust.** Power tools create sparks which may ignite the dust or fumes.
- c) **Keep children and bystanders away while operating a power tool.** Distractions can cause you to lose control.

## 2. ELECTRICAL SAFETY

- a) **Power tool plugs must match the outlet. Never modify the plug in any way. Do not use any adapter plugs with earthed (grounded) power tools.** Unmodified plugs and matching outlets will reduce risk of electric shock.
- b) **Avoid body contact with earthed or grounded surfaces, such as pipes, radiators, ranges and refrigerators.** There is an increased risk of electric shock if your body is earthed or grounded.
- c) **Do not expose power tools to rain or wet conditions.** Water entering a power tool will increase the risk of electric shock.
- d) **Do not abuse the cord. Never use the cord for carrying, pulling or unplugging the power tool. Keep cord away from heat, oil, sharp edges or moving parts.** Damaged or entangled cords increase the risk of electric shock.
- e) **When operating a power tool outdoors, use an extension cord suitable for outdoor use.** Use of a cord suitable for outdoor use reduces the risk of electric shock.
- f) **If operating a power tool in a damp location is unavoidable, use a residual current device (RCD) protected supply.** Use of an RCD reduces the risk of electric shock.

## 3. PERSONAL SAFETY

- a) **Stay alert, watch what you are doing and use common sense when operating a power tool. Do not use a power tool while you are tired or under the influence of drugs, alcohol or medication.** A moment of inattention while operating power tools may result in serious personal injury.

- b) **Use personal protective equipment. Always wear eye protection.** Protective equipment such as dust mask, non-skid safety shoes, hard hat, or hearing protection used for appropriate conditions will reduce personal injuries.
- c) **Prevent unintentional starting. Ensure the switch is in the off-position before connecting to power source and/or battery pack, picking up or carrying the tool.** Carrying power tools with your finger on the switch or energising power tools that have the switch on invites accidents.
- d) **Remove any adjusting key or wrench before turning the power tool on.** A wrench or a key left attached to a rotating part of the power tool may result in personal injury.
- e) **Do not overreach. Keep proper footing and balance at all times.** This enables better control of the power tool in unexpected situations.
- f) **Dress properly. Do not wear loose clothing or jewellery. Keep your hair, clothing and gloves away from moving parts.** Loose clothes, jewellery or long hair can be caught in moving parts.
- g) **If devices are provided for the connection of dust extraction and collection facilities, ensure these are connected and properly used.** Use of dust collection can reduce dust-related hazards.
- h) **Do not let familiarity gained from frequent use of tools allow you to become complacent and ignore tool safety principles.** A careless action can cause severe injury within a fraction of a second.

## 4. POWER TOOL USE AND CARE

- a) **Do not force the power tool. Use the correct power tool for your application.** The correct power tool will do the job better and safer at the rate for which it was designed.
- b) **Do not use the power tool if the switch does not turn it on and off.** Any power tool that cannot be controlled with the switch is dangerous and must be repaired.
- c) **Disconnect the plug from the power source and/or the battery pack from the power tool before making any adjustments, changing accessories, or storing power tools.** Such preventive safety measures reduce the risk of starting the power tool accidentally.
- d) **Store idle power tools out of the reach of children and do not allow persons unfamiliar with the power tool or these instructions to operate the power tool.** Power tools are dangerous in the hands of untrained users.
- e) **Maintain power tools. Check for misalignment or binding of moving parts, breakage of parts and any other condition that may affect the power tool's operation. If damaged, have the power tool repaired before use.** Many accidents are caused by poorly maintained power tools.
- f) **Keep cutting tools sharp and clean.** Properly maintained cutting tools with sharp cutting edges are less likely to bind and are easier to control.
- g) **Use the power tool, accessories and tool**

bits etc. in accordance with these instructions, taking into account the working conditions and the work to be performed. Use of the power tool for operations different from those intended could result in a hazardous situation.

**h) Keep handles and grasping surfaces dry, clean and free from oil and grease.** Slippery handles and grasping surfaces do not allow for safe handling and control of the tool in unexpected situations.

**5. SERVICE**

**a) Have your power tool serviced by a qualified repair person using only identical replacement parts.** This will ensure that the safety of the power tool is maintained.

**Additional safety rules:**

**1) Recommendation that the tool always be supplied via a residual current device with a rated residual current of 30 mA or less.**

**SYMBOLS**

	To reduce the risk of injury, user must read instruction manual
	Double insulation
	Warning
	Wear ear protection
	Wear eye protection
	Wear dust mask
 N5112	RCM marking
<b>ABN:</b> Australian Business Number. By this number, business information such as entity type, status, business location etc. can be found at website <a href="http://abr.business.gov.au">http://abr.business.gov.au</a> . ABN of Positec Australia Pty Limited is 14 101 682 357	

- 1. ON/OFF SWITCH**
- 2. SOFT GRIP HANDLE**
- 3. VARIABLE SPEED CONTROL**
- 4. CYCLONIC DUST BOX**
- 5. LATCHING LEVER**
- 6. DUST EXTRACTION OUTLET**
- 7. OUTER BASE PLATE**
- 8. INNER BASE PLATE**
- 9. MOTOR HOUSING**
- 10. A: INNER SPOT PAPER\*(SEE FIG A)  
B: OUTER RING PAPER\*(SEE FIG A)**
- 11. DUST EXTRACTION ADAPTOR(SEE FIG D)**

\* Not all the accessories illustrated or described are included in standard delivery.

**TECHNICAL DATA**

Type **WX655 (650-659-designation of machinery, representative of Random orbital sander)**

Voltage	230-240V~50Hz
Power Input	390W
No-load speed	6000-13800/min
Base size	125mm
Orbital diameter	3mm
Protection class	 /11
Machine weight	1.7kg

**ACCESSORY**

Cyclone Dust Box	1
60 grit velcro sanding paper	10
120 grit velcro sanding paper	10
180 grit velcro sanding paper	10
Dust extraction adapter	1

We recommend that you purchase your accessories from the same store that sold you the tool. Refer to the accessory packaging for further details. Store personnel can assist you and offer advice.



## OPERATING INSTRUCTIONS



**NOTE:** Before using the tool, read the instruction book carefully.

### INTENDED USE:

The machine is intended for dry sanding of wood, plastic, metal and filler material as well as painted surfaces.

Machines with electronic control are also suitable for polishing.

### ASSEMBLY AND OPERATION

Action	Figure
<b>ASSEMBLY</b>	
Fitting the Sanding Paper	See Fig. A1, A2
<b>Attaching the Cyclone Dust Box</b>  <b>CAUTION:</b> To prevent the possibility of sanding dust or foreign body being thrown into your face or eyes, never attempt to use your sander without the dust box properly installed.	See Fig. B
<b>Emptying the Cyclone Dust Box</b> For more efficient operation, empty dusts box every 5-10mins.	See Fig. C1, C2
Using the dust extraction adapter	See Fig. D
<b>OPERATION</b>	
On/Off Switch	See Fig. E
<b>Variable speed control</b> With the variable speed control, the required speed can be selected (also while running). The required speed is dependent on the material and is to be determined by a practical trial. After longer periods of working at low speed, allow the machine to cool down by running it for approx. 3 minutes at maximum speed with no load.	See Fig. F
Orbital sanding	See Fig G
<b>Selecting the right grade of sandpaper</b> <b>NOTE:</b> The sandpaper is Different grades of sanding sheet . Available grades range from coarse to fine. This machine can only fit special sanding paper, which can be purchased from the store where the sander was purchased, or www.worx.com.	
Changing the Outer/Inner Pad	See Fig H1, H2, H3, H4

## WORKING HINTS FOR YOUR SANDER

If your power tool becomes too hot, especially when used at low speed, set the speed to maximum and run it with no load for 2-3 minutes to cool the motor. Avoid prolonged usage at very low speeds. Always use sand paper that is suitable for the material you want to sand. Always ensure the work-piece is firmly held or clamped to prevent movement.

Any movement of the material may affect the quality of the sanding finish.

Start your sander before sanding and turn it off only after you stop sanding. For the best results, sand wood in the direction of the grain.

Do not start sanding without having the sandpaper fitted.

Do not allow the sand paper to wear away it will damage the base-plate. The guarantee does not cover base-plate wear and tear.

Use coarse grit paper to sand rough surfaces, medium grit for smooth surfaces and fine grit for the final surfaces. If necessary, first make a test run on scrap material.

Use only good quality sand paper.

The sand paper controls the sanding efficiency, not the amount of force you apply to the tool. Excessive force will reduce the sanding efficiency and cause motor overload. Replacing the sand paper regularly will maintain optimum sanding efficiency.

An integrated sanding plate brake reduces the speed when running at no load so that scoring is avoided when placing the machine on the work piece. A continuously increasing no-load speed over the course of time indicates that the sanding plate brake is worn and must be replaced by an authorized customer service location.

## MAINTAIN TOOLS WITH CARE

**Remove the plug from the socket before carrying out any adjustment, servicing or maintenance.**

Your power tool requires no additional lubrication or maintenance. There are no user serviceable parts in your power tool. Never use water or chemical cleaners to clean your power tool. Wipe clean with a dry cloth. Always store your power tool in a dry place. Keep the motor ventilation slots clean. Keep all working controls free of dust. Occasionally you may see sparks through the ventilation slots. This is normal. If the supply cord is damaged, it must be replaced by the manufacturer, its service agent or similarly qualified persons in order to avoid a hazard.







**[www.worx.com](http://www.worx.com)**

Copyright © 2017, Positec. All Rights Reserved.  
AR01341800