

# WORX®

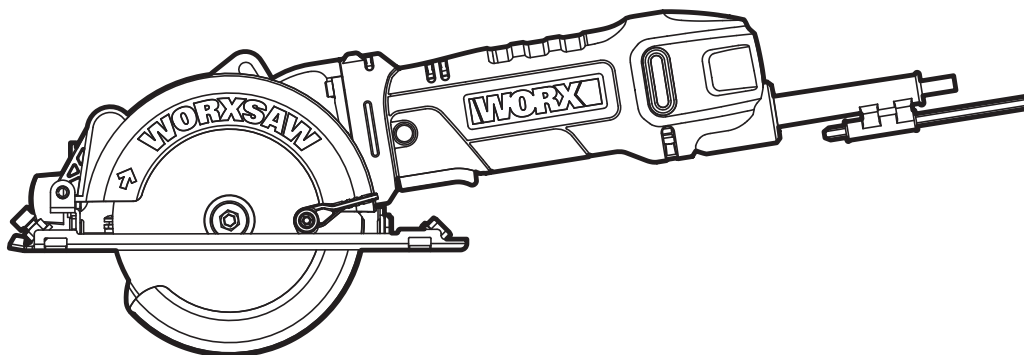

## WORXSAW<sup>XL</sup>

<b>Compact Circular Saw</b>	<b>EN</b>	<b>P08</b>
<b>Elektrische kreissäge</b>	<b>D</b>	<b>P18</b>
<b>Scie circulaire électrique</b>	<b>F</b>	<b>P28</b>
<b>Motosega circolare elettrica</b>	<b>I</b>	<b>P38</b>
<b>Sierra circular eléctrica</b>	<b>ES</b>	<b>P48</b>
<b>Elektrische cirkelzaag</b>	<b>NL</b>	<b>P58</b>
<b>Pilarka elektryczna</b>	<b>PL</b>	<b>P68</b>
<b>Elektromos körfűrész</b>	<b>HU</b>	<b>P78</b>
<b>Ferăstrău circular electric</b>	<b>RO</b>	<b>P88</b>
<b>Elektrická okružní píla</b>	<b>CZ</b>	<b>P98</b>
<b>Elektrická okružná píla</b>	<b>SK</b>	<b>P107</b>
<b>Serra circular eléctrica</b>	<b>PT</b>	<b>P116</b>
<b>Elektrisk cirkelsåg</b>	<b>SV</b>	<b>P126</b>
<b>Električna krožna žaga</b>	<b>SL</b>	<b>P135</b>

# WX439

<b>Original instructions</b>	<b>EN</b>
<b>Originalbetriebsanleitung</b>	<b>D</b>
<b>Notice originale</b>	<b>F</b>
<b>Istruzioni originali</b>	<b>I</b>
<b>Manual original</b>	<b>ES</b>
<b>Oorspronkelijke gebruiksaanwijzing</b>	<b>NL</b>
<b>Instrukcja oryginalna</b>	<b>PL</b>
<b>Eredeti használati utasítás</b>	<b>HU</b>
<b>Instrucțiuni originale</b>	<b>RO</b>
<b>Původní návod k používání</b>	<b>CZ</b>
<b>Pôvodný návod na použitie</b>	<b>SK</b>
<b>Manual original</b>	<b>PT</b>
<b>Bruksanvisning i original</b>	<b>SV</b>
<b>Izvirna navodila</b>	<b>SL</b>

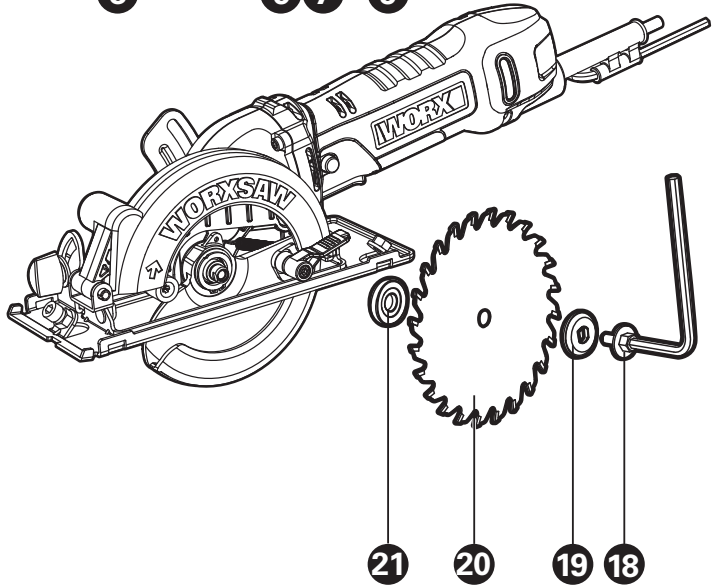
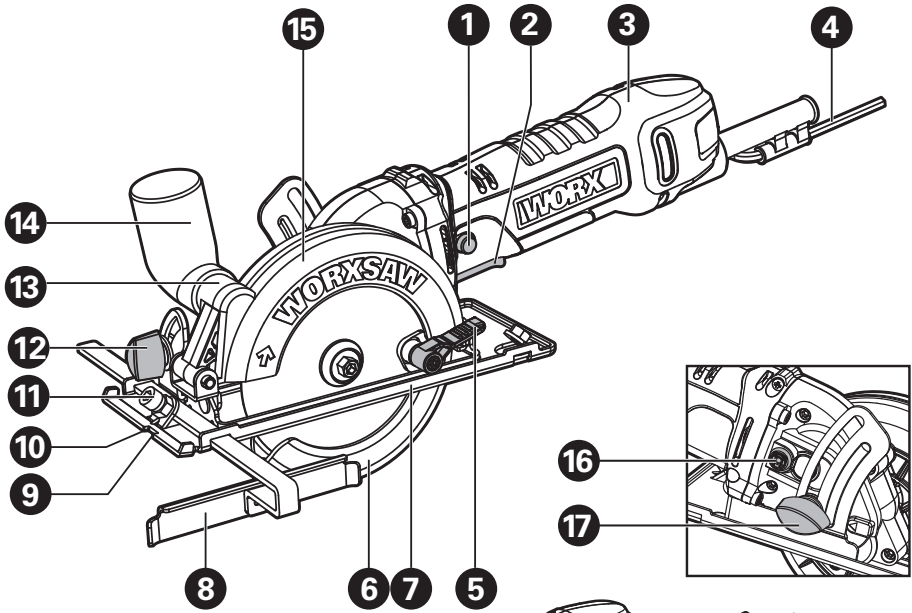

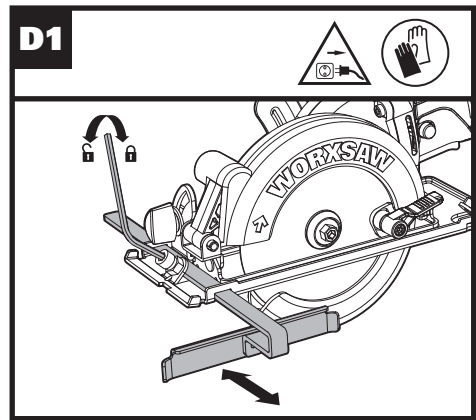
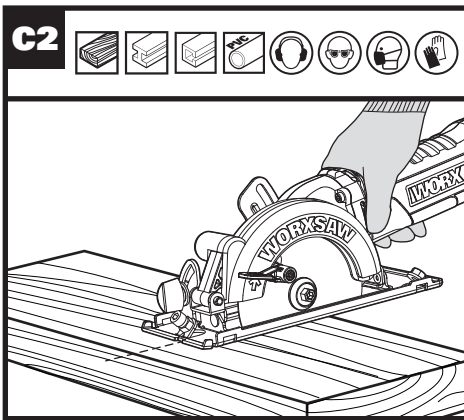
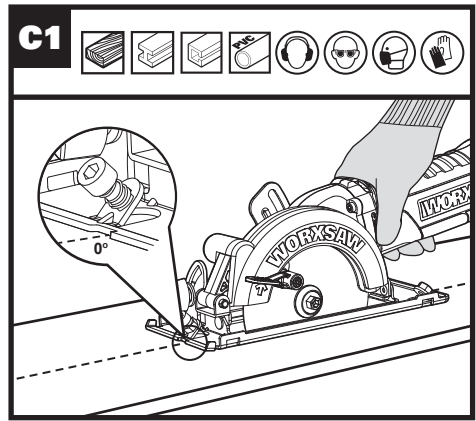
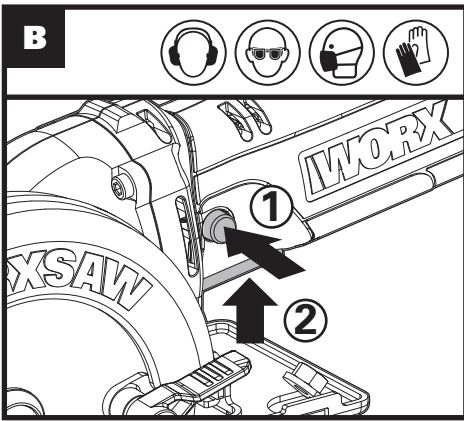
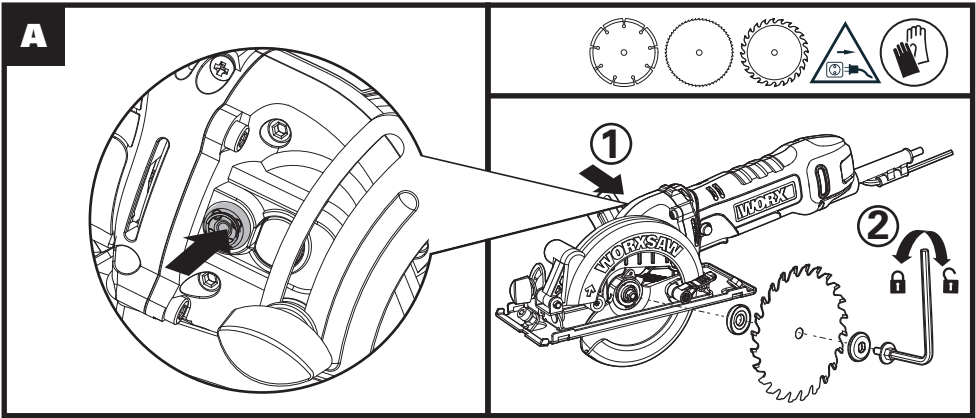

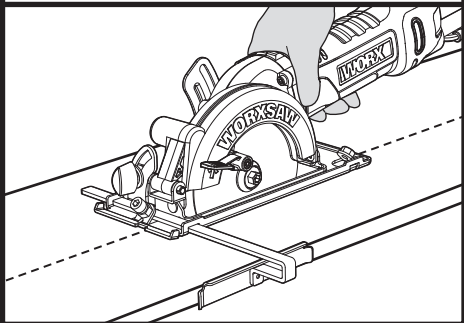
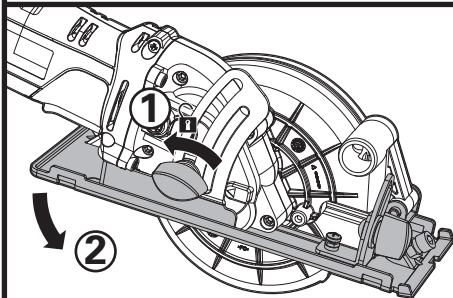
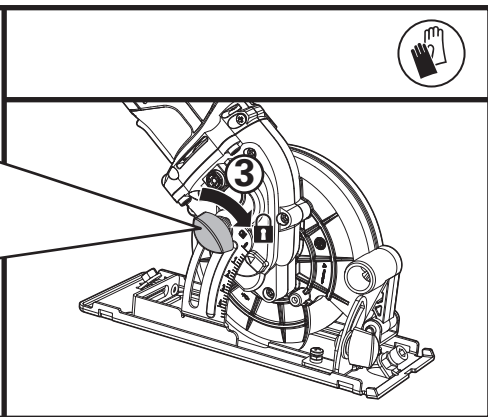
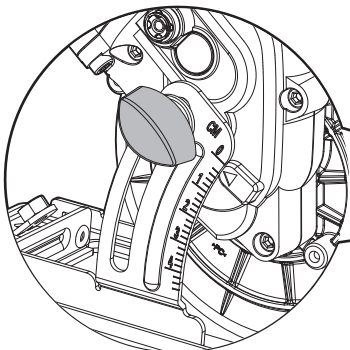
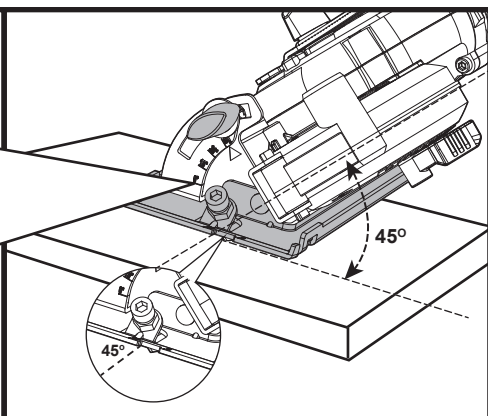
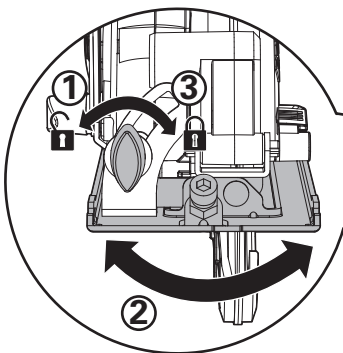
**D2****E1****E2****F**

G1

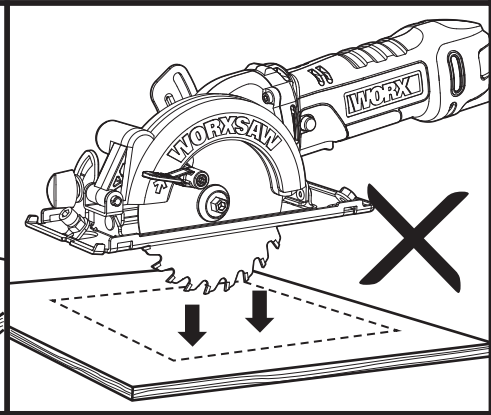
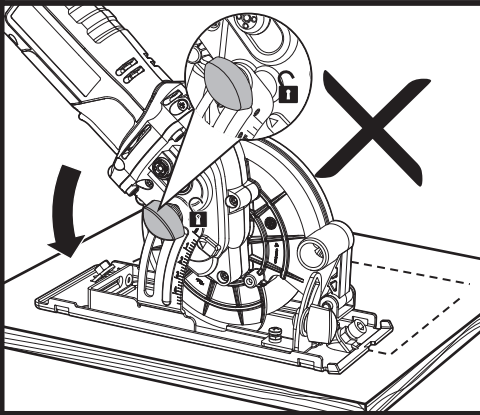
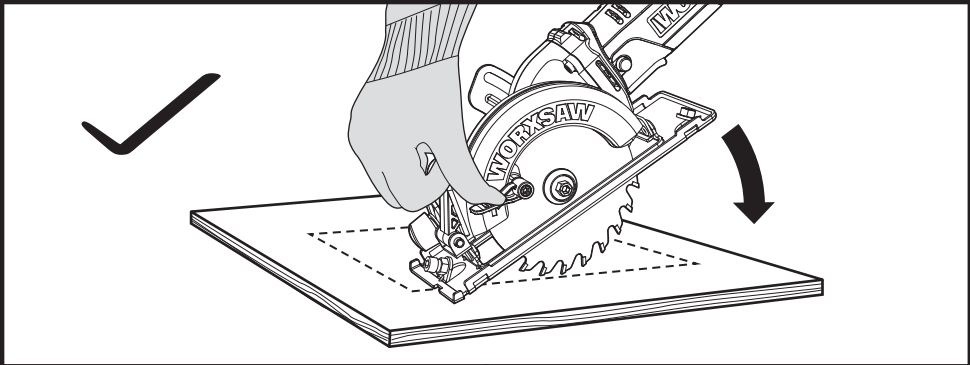

G2

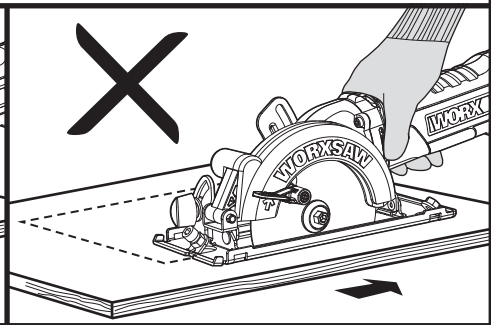
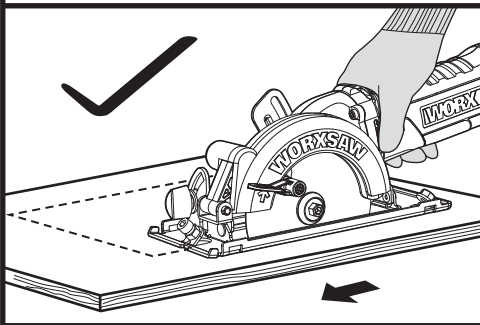

H

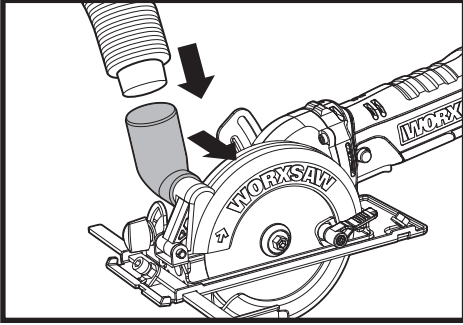

# GENERAL POWER TOOL SAFETY WARNINGS



**WARNING! Read all safety warnings and all instructions.** Failure to follow the warnings and instructions may result in electric shock, fire and/or serious injury.

## Save all warnings and instructions for future reference.

The term "power tool" in the warnings refers to your mains-operated (corded) power tool or battery-operated (cordless) power tool.

### 1) Work area safety

- a) **Keep work area clean and well lit.** Cluttered or dark areas invite accidents.
- b) **Do not operate power tools in explosive atmospheres, such as in the presence of flammable liquids, gases or dust.** Power tools create sparks which may ignite the dust or fumes.
- c) **Keep children and bystanders away while operating a power tool.** Distractions can cause you to lose control.

### 2) Electrical safety

- a) **Power tool plugs must match the outlet. Never modify the plug in any way. Do not use any adapter plugs with earthed (grounded) power tools.** Unmodified plugs and matching outlets will reduce risk of electric shock.
- b) **Avoid body contact with earthed or grounded surfaces, such as pipes, radiators, ranges and refrigerators.** There is an increased risk of electric shock if your body is earthed or grounded.
- c) **Do not expose power tools to rain or wet conditions.** Water entering a power tool will increase the risk of electric shock.
- d) **Do not abuse the cord. Never use the cord for carrying, pulling or unplugging the power tool. Keep cord away from heat, oil, sharp edges or moving parts.** Damaged or entangled cords increase the risk of electric shock.
- e) **When operating a power tool outdoors, use an extension cord suitable for outdoor use.** Use of a cord suitable for outdoor use reduces the risk of electric shock.
- f) **If operating a power tool in a damp location is unavoidable, use a residual current device (RCD) protected supply.** Use of an RCD reduces the risk of electric shock.

### 3) Personal safety

- a) **Stay alert, watch what you are doing and use common sense when operating a power tool. Do not use a power tool while you are tired or under the influence of drugs, alcohol or medication.** A moment of inattention while operating power tools may result in serious personal injury.

- b) **Use personal protective equipment. Always wear eye protection.** Protective equipment such as dust mask, non-skid safety shoes, hard hat, or hearing protection used for appropriate conditions will reduce personal injuries.

- c) **Prevent unintentional starting. Ensure the switch is in the off-position before connecting to power source and/or battery pack, picking up or carrying the tool.**

Carrying power tools with your finger on the switch or energising power tools that have the switch on invites accidents.

- d) **Remove any adjusting key or wrench before turning the power tool on.** A wrench or a key left attached to a rotating part of the power tool may result in personal injury.
- e) **Do not overreach. Keep proper footing and balance at all times.** This enables better control of the power tool in unexpected situations.
- f) **Dress properly. Do not wear loose clothing or jewellery. Keep your hair, clothing and gloves away from moving parts.** Loose clothes, jewellery or long hair can be caught in moving parts.
- g) **If devices are provided for the connection of dust extraction and collection facilities, ensure these are connected and properly used.** Use of dust collection can reduce dust-related hazards.

### 4) Power tool use and care

- a) **Do not force the power tool. Use the correct power tool for your application.** The correct power tool will do the job better and safer at the rate for which it was designed.
- b) **Do not use the power tool if the switch does not turn it on and off.** Any power tool that cannot be controlled with the switch is dangerous and must be repaired.
- c) **Disconnect the plug from the power source and/or the battery pack from the power tool before making any adjustments, changing accessories, or storing power tools.** Such preventive safety measures reduce the risk of starting the power tool accidentally.
- d) **Store idle power tools out of the reach of children and do not allow persons unfamiliar with the power tool or these instructions to operate the power tool.** Power tools are dangerous in the hands of untrained users.
- e) **Maintain power tools. Check for misalignment or binding of moving parts, breakage of parts and any other condition that may affect the power tool's operation. If damaged, have the power tool repaired before use.** Many accidents are caused by poorly maintained power tools.
- f) **Keep cutting tools sharp and clean.** Properly maintained cutting tools with sharp cutting edges are less likely to bind and are easier to control.
- g) **Use the power tool, accessories and tool bits etc. in accordance with these instructions, taking into account the**



**working conditions and the work to be performed.** Use of the power tool for operations different from those intended could result in a hazardous situation.

## 5) Service

- a) **Have your power tool serviced by a qualified repair person using only identical replacement parts.** This will ensure that the safety of the power tool is maintained.

## SAFETY WARNINGS FOR ALL SAWS

- a)  **DANGER: Keep hands away from cutting area and the blade.** If both hands are holding the saw, they cannot be cut by the blade.
- b) **Do not reach underneath the workpiece.** The guard cannot protect you from the blade below the workpiece.
- c) **Adjust the cutting depth to the thickness of the workpiece.** Less than a full tooth of the blade teeth should be visible below the workpiece.
- d) **Never hold piece being cut in your hands or across your leg. Secure the workpiece to a stable platform.** It is important to support the work properly to minimize body exposure, blade binding, or loss of control.
- e) **Hold the power tool by insulated gripping surfaces only, when performing an operation where the cutting tool may contact hidden wiring or its own cord.** Contact with a "live" wire will also make exposed metal parts of the power tool "live" and could give the operator an electric shock.
- f) **When ripping always use a rip fence or straight edge guide.** This improves the accuracy of cut and reduces the chance of blade binding.
- g) **Always use blades with correct size and shape (diamond versus round) of arbour holes.** Blades that do not match the mounting hardware of the saw will run eccentrically, causing loss of control.
- h) **Never use damaged or incorrect blade washers or bolt.** The blade washers and bolt were specially designed for your saw, for optimum performance and safety of operation.
- saw to lift up and out of the workpiece toward the operator;
- when the blade is pinched or bound tightly by the kerf closing down, the blade stalls and the motor reaction drives the unit rapidly back toward the operator;
- if the blade becomes twisted or misaligned in the cut, the teeth at the back edge of the blade can dig into the top surface of the wood causing the blade to climb out of the kerf and jump back toward the operator.
- Kickback is the result of saw misuse and/or incorrect operating procedures or conditions and can be avoided by taking proper precautions as given below.
- a) **Maintain a firm grip on the saw and position your arms to resist kickback forces. Position your body to either side of the blade, but not in line with the blade.** Kickback could cause the saw to jump backwards, but kickback forces can be controlled by the operator, if proper precautions are taken.
- b) **When blade is binding, or when interrupting a cut for any reason, release the trigger and hold the saw motionless in the material until the blade comes to a complete stop. Never attempt to remove the saw from the work or pull the saw backward while the blade is in motion or kickback may occur.** Investigate and take corrective actions to eliminate the cause of blade binding.
- c) **When restarting a saw in the workpiece, centre the saw blade in the kerf and check that saw teeth are not engaged into the material.** If saw blade is binding, it may walk up or kickback from the workpiece as the saw is restarted.
- d) **Support large panels to minimise the risk of blade pinching and kickback. Large panels tend to sag under their own weight.** Supports must be placed under the panel on both sides, near the line of cut and near the edge of the panel.
- e) **Do not use dull or damaged blades.** Unsharpened or improperly set blades produce narrow kerf causing excessive friction, blade binding and kickback.
- f) **Blade depth and bevel adjusting locking levers must be tight and secure before making cut.** If blade adjustment shifts while cutting, it may cause binding and kickback.
- g) **Use extra caution when sawing into existing walls or other blind areas.** The protruding blade may cut objects that can cause kickback.

## FURTHER SAFETY INSTRUCTIONS FOR ALL SAWS

### Kickback causes and related warnings

- kickback is a sudden reaction to a pinched, bound or misaligned saw blade, causing an uncontrolled

## SAFETY INSTRUCTIONS FOR SAWS WITH INNER PENDULUM GUARD

### Lower Guard Function

- a) **Check lower guard for proper closing**

before each use. Do not operate the saw if lower guard does not move freely and close instantly. Never clamp or tie the lower guard into the open position. If saw is accidentally dropped, lower guard may be bent. Raise the lower guard with the retracting handle and make sure it moves freely and does not touch the blade or any other part, in all angles and depths of cut.

- b) Check the operation of the lower guard spring. If the guard and the spring are not operating properly, they must be serviced before use. Lower guard may operate sluggishly due to damaged parts, gummy deposits, or a build-up of debris.
- c) Lower guard may be retracted manually only for special cuts such as "plunge cuts" and "compound cuts." Raise lower guard by retracting handle and as soon as blade enters the material, the lower guard must be released. For all other sawing, the lower guard should operate automatically.
- d) Always observe that the lower guard is covering the blade before placing saw down on bench or floor. An unprotected, coasting blade will cause the saw to walk backwards, cutting whatever is in its path. Be aware of the time it takes for the blade to stop after switch is released.

wheel. Proper wheel flanges support the wheel thus reducing the possibility of wheel breakage.

- f) Do not use worn down reinforced wheels from larger power tools. Wheels intended for a larger power tool are not suitable for the higher speed of a smaller tool and may burst.
- g) The outside diameter and the thickness of your accessory must be within the capacity rating of your power tool. Incorrectly sized accessories cannot be adequately guarded or controlled.
- h) The arbour size of wheels and flanges must properly fit the spindle of the power tool. Wheels and flanges with arbour holes that do not match the mounting hardware of the power tool will run out of balance, vibrate excessively and may cause loss of control.
- i) Do not use damaged wheels. Before each use, inspect the wheels for chips and cracks. If power tool or wheel is dropped, inspect for damage or install an undamaged wheel. After inspecting and installing the wheel, position yourself and bystanders away from the plane of the rotating wheel and run the power tool at maximum no load speed for one minute. Damaged wheels will normally break apart during this test time.
- j) Wear personal protective equipment. Depending on application, use face shield, safety goggles or safety glasses. As appropriate, wear dust mask, hearing protectors, gloves and shop apron capable of stopping small abrasive or workpiece fragments. The eye protection must be capable of stopping flying debris generated by various operations. The dust mask or respirator must be capable of filtrating particles generated by your operation. Prolonged exposure to high intensity noise may cause hearing loss.
- k) Keep bystanders a safe distance away from work area. Anyone entering the work area must wear personal protective equipment. Fragments of workpiece or of a broken wheel may fly away and cause injury beyond immediate area of operation.
- l) Hold the power tool by insulated gripping surfaces only, when performing an operation where the cutting accessory may contact hidden wiring or its own cord. Cutting accessory contacting a "live" wire may make exposed metal parts of the power tool "live" and could give the operator an electric shock.
- m) Position the cord clear of the spinning accessory. If you lose control, the cord may be cut or snagged and your hand or arm may be pulled into the spinning wheel.
- n) Never lay the power tool down until the accessory has come to a complete stop. The spinning wheel may grab the surface and pull the power tool out of your control.
- o) Do not run the power tool while carrying it at your side. Accidental contact with the

## ADDITIONAL SAFETY RULES FOR YOUR CUTTING-OFF MACHINES

- a) The guard provided with the tool must be securely attached to the power tool and positioned for maximum safety, so the least amount of wheel is exposed towards the operator. Position yourself and bystanders away from the plane of the rotating wheel. The guard helps to protect operator from broken wheel fragments and accidental contact with wheel.
- b) Use only bonded reinforced or diamond cut-off wheels for your power tool. Just because an accessory can be attached to your power tool, it does not assure safe operation.
- c) The rated speed of the accessory must be at least equal to the maximum speed marked on the power tool. Accessories running faster than their rated speed can break and fly apart.
- d) Wheels must be used only for recommended applications. For example: do not grind with the side of cut-off wheel. Abrasive cut-off wheels are intended for peripheral grinding, side forces applied to these wheels may cause them to shatter.
- e) Always use undamaged wheel flanges that are of correct diameter for your selected

spinning accessory could snag your clothing, pulling the accessory into your body.

**p) Regularly clean the power tool's air vents.**

The motor's fan will draw the dust inside the housing and excessive accumulation of powdered metal may cause electrical hazards.

**q) Do not operate the power tool near flammable materials.** Sparks could ignite these materials.

**r) Do not use accessories that require liquid coolants.** Using water or other liquid coolants may result in electrocution or shock.

## KICKBACK AND RELATED WARNINGS

- Kickback is a sudden reaction to a pinched or snagged rotating wheel. Pinching or snagging causes rapid stalling of the rotating wheel which in turn causes the uncontrolled power tool to be forced in the direction opposite of the wheel's rotation at the point of the binding.

- For example, if an abrasive wheel is snagged or pinched by the workpiece, the edge of the wheel that is entering into the pinch point can dig into the surface of the material causing the wheel to climb out or kick out. -The wheel may either jump toward or away from the operator, depending on direction of the wheel's movement at the point of pinching. Abrasive wheels may also break under these conditions.

Kickback is the result of power tool misuse and/or incorrect operating procedures or conditions and can be avoided by taking proper precautions as given below.

**a) Maintain a firm grip on the power tool and position your body and arm to allow you to resist kickback forces. Always use auxiliary handle, if provided, for maximum control over kickback or torque reaction during start-up.** The operator can control torque reactions or kickback forces, if proper precautions are taken.

**b) Never place your hand near the rotating accessory.** Accessory may kickback over your hand.

**c) Do not position your body in line with the rotating wheel.** Kickback will propel the tool in direction opposite to the wheel's movement at the point of snagging.

**d) Use special care when working corners, sharp edges etc. Avoid bouncing and snagging the accessory.** Corners, sharp edges or bouncing have a tendency to snag the rotating accessory and cause loss of control or kickback.

**e) Do not attach a saw chain, woodcarving blade, segmented diamond wheel with a peripheral gap greater than 10 mm or toothed saw blade.** Such blades create frequent kickback and loss of control.

**f) Do not "jam" the wheel or apply excessive**

**pressure. Do not attempt to make an excessive depth of cut.** Overstressing the wheel increases the loading and susceptibility to twisting or binding of the wheel in the cut and the possibility of kickback or wheel breakage.

**g) When wheel is binding or when interrupting a cut for any reason, switch off the power tool and hold the power tool motionless until the wheel comes to a complete stop. Never attempt to remove the wheel from the cut while the wheel is in motion otherwise kickback may occur.** Investigate and take corrective action to eliminate the cause of wheel binding.

**h) Do not restart the cutting operation in the workpiece. Let the wheel reach full speed and carefully re-enter the cut.** The wheel may bind, walk up or kickback if the power tool is restarted in the workpiece.

**i) Support panels or any oversized workpiece to minimize the risk of wheel pinching and kickback. Large workpieces tend to sag under their own weight.** Supports must be placed under the workpiece near the line of cut and near the edge of the workpiece on both sides of the wheel.

**j) Use extra caution when making a "pocket cut" into existing walls or other blind areas.** The protruding wheel may cut gas or water pipes, electrical wiring or objects that can cause kickback.

## ADDITIONAL SAFETY RULES FOR CIRCULAR SAW

1. Always wear a dust mask, hearing protection and eye protection.
2. Only use saw blades recommended in the specification.
3. Use only blade diameter(s) in accordance with the markings.

# SYMBOLS

	To reduce the risk of injury, user must read instruction manual
	Double insulation
	Warning
	Wear ear protection
	Wear eye protection
	Wear dust mask
	Waste electrical products must not be disposed of with household waste. Please recycle where facilities exist. Check with your local authorities or retailer for recycling advice.
	Before any work on the machine itself, pull the mains plug from the socket outlet.
	Wear protective gloves
	Wood
	Aluminium
	Metal
	Plastic
	Incorrect

	Correct
	Lock
	Unlock
	Diamond disc
	HCS blade
	TCT blade

# COMPONENT LIST

1. SAFETY SWITCH
2. ON/OFF TRIGGER
3. SOFT GRIP HANDLE
4. HEX KEY
5. BLADE GUARD LEVER
6. BLADE GUARD
7. BASE PLATE
8. PARALLEL GUIDE
9. CUTTING MARK, 0°
10. CUTTING MARK, 45°
11. PARALLEL GUIDE CLAMPING FIXTURE
12. BEVEL ADJUSTMENT LEVER
13. DUST EXTRACTION OUTLET
14. VACUUM ADAPTER
15. FIXED UPPER BLADE GUARD
16. SPINDLE LOCK BUTTON
17. DEPTH ADJUSTMENT LEVER
18. BLADE BOLT
19. OUTER FLANGE
20. SAW BLADE
21. INNER FLANGE

**Not all the accessories illustrated or described are included in standard delivery.**

## TECHNICAL DATA

Type **WX439 (4 - designation of machinery, representative of Saw)**

Voltage		230-240V~50Hz
Rated power		480W
No load (rated) speed		4500/min
Blade size	TCT blade	120mmx1.2mmx9.5mmx24T
	HCS blade	115mmx1.2mmx9.5mmx60T
	Diamond disc	115mmx1.6mmx9.5mmx60G
Bevel capacity		0-45°
Cutting capacity	Cutting Depth at 90°	46mm
	Cutting Depth at 45°	30mm
Arbor Size		9.5mm
Recommended maximum material thickness	Wood	46mm
	Aluminum	2.5mm
	PVC pipe (diameter)	46mm
	Tile	12mm
	Sheet steel	0.5mm
Saw blade thickness	TCT blade	0.8mm
	HCS blade	1mm
	Diamond disc	1mm
Spindle thread size		M6
Protection class		
Bare tool weight		2kg

## NOISE INFORMATION

A weighted sound pressure	$L_{pA}$ : 83dB(A)
A weighted sound power:	$L_{WA}$ : 93dB(A)
$K_{pA}$ & $K_{WA}$ :	3.0dB(A)

**Wear ear protection.**

## VIBRATION INFORMATION

Vibration total values (triax vector sum) determined according to EN 60745:

Vibration emission value:	Cutting wood: $a_{h,W} = 2.55\text{m/s}^2$
	Uncertainty K = 1.5m/s <sup>2</sup>
	Cutting metal: $a_{h,M} = 3.00\text{m/s}^2$
	Uncertainty K = 1.5m/s <sup>2</sup>
	Cutting tile: $a_{h,T} = 4.93\text{m/s}^2$
	Uncertainty K = 1.5m/s <sup>2</sup>

The declared vibration total value may be used for comparing one tool with another, and may also be used in a preliminary assessment of exposure.

**WARNING:** The vibration emission value during actual use of the power tool can differ from the declared value depending on the ways in which the tool is used dependant on the following examples and other variations on how the tool is used:

How the tool is used and the materials being cut or drilled.

The tool being in good condition and well maintained  
The use the correct accessory for the tool and ensuring it is sharp and in good condition.

The tightness of the grip on the handles and if any anti vibration accessories are used.

And the tool is being used as intended by its design and these instructions.

**This tool may cause hand-arm vibration syndrome if its use is not adequately managed.**

**WARNING:** To be accurate, an estimation of exposure level in the actual conditions of use should also take account of all parts of the operating cycle such as the times when the tool is switched off and when it is running idle but not actually doing the job. This may significantly reduce the exposure level over the total working period.

Helping to minimise your vibration exposure risk.  
ALWAYS use sharp chisels, drills and blades  
Maintain this tool in accordance with these instructions and keep well lubricated (where appropriate)

If the tool is to be used regularly then invest in anti vibration accessories.  
Plan your work schedule to spread any high vibration tool use across a number of days.

## ACCESSORIES

<b>Parallel guide</b>	<b>1</b>
<b>Hex key</b>	<b>1</b>
<b>Vacuum adapter</b>	<b>1</b>
<b>24T TCT Blade (WA5046)</b>	<b>1</b>
<b>HCS Blade (WA8302)</b>	<b>1</b>
<b>Diamond disc (WA5048)</b>	<b>1</b>

We recommend that you purchase your accessories listed in the above list from the same store that sold you the tool. Refer to the accessory packaging for further details. Store personnel can assist you and offer advice.

## OPERATING INSTRUCTIONS



**NOTE:** Before using the tool, read the instruction book carefully.



### WARNING:

Do not release the handle until the saw blade come to complete stop and do not touch saw blade while the saw blade is running.

### INTENDED USE:

The tool is intended for ripping and cross-cutting wood and other materials in straight cutting lines, while resting firmly on the work piece.

## ASSEMBLY AND OPERATION

Action	Figure
Mounting and Removing the Blade	See Fig. A
Safety switch and On/Off trigger	See Fig. B
Rip and Cross Cutting	See Fig. C1, C2
Parallel Guide	See Fig. D1, D2
Adjusting the Cutting Depth	See Fig. E1, E2
Adjusting the Cutting Angle	See Fig. F
Pocket /Plunge	See Fig. G1, G2
Sawdust Removal	See Fig. H

## WORKING HINTS FOR YOUR TOOL

If your power tool becomes too hot, please run your circular saw no load for 2-3 minutes to cool the motor. Avoid prolonged usage at very low speeds. Protect saw blades against impact and shock. Cutting with extreme force can significantly reduces the performance capability of the tool and reduces the service life of the saw blade. Sawing performance and cutting quality depend essentially on the condition and the tooth count of the saw blade.

Therefore, use only sharp saw blades that are suited for the material being cut.

Choice of blades: 24 teeth for general work, approx. 40 teeth for finer cuts, more than 40 teeth for very fine cuts into delicate surfaces, diamond for tile, cement board, etc.

Only use saw blades recommended.

## MAINTAIN TOOLS WITH CARE

**Remove the plug from the socket before carrying out any adjustment, servicing or maintenance.**

Keep tools sharp and clean for better and safer performance. Follow instructions for lubricating and changing accessories. Inspect tool cords periodically and if damaged, have repaired by authorized service facility. Your power tool requires no additional lubrication or maintenance. There are no user serviceable parts in your power tool. Never use water or chemical cleaners to clean your power tool. Wipe clean with a dry cloth. Always store your power tool in a dry place. Keep the motor ventilation slots clean. Keep all working controls free of dust.

If the supply cord is damaged, it must be replaced by the manufacturer, its service agent or similarly qualified persons in order to avoid a hazard. Periodically clear dust and chips from guard and base to ensure proper performance.

## ENVIRONMENTAL PROTECTION



Waste electrical products must not be disposed of with household waste. Please recycle where facilities exist. Check with your local authorities or retailer for recycling advice.

# TROUBLE SHOOTING

Symptom	Possible Causes	Possible Solution
Tool will not start when operating the on/off trigger.	Safety switch is not pressed. Power cord not plugged in. Power cord is broken. Carbon brush has worn down	Press safety switch and hold it while engaging the on/off trigger. Check to make sure power cord is connected well into a working outlet. Unplug the power cord and replace it using a qualified maintenance person. Replace the carbon brush using a qualified maintenance person.
Cutting depth is less than that is set.	Sawdust accumulated at the rear of the base.	Shake out sawdust. Consider connecting a vacuum for dust collection.
Blade spins or slips.	Blade is not tightly engaged with the spindle.	Remove the blade and reassemble it as described in <b>Mounting and Removing the Blade</b> section.
Blade will not cut a straight line.	Blade is dull. Blade is not mounted properly. Saw is not being guided properly.	Mount a new, sharp blade on the saw. Check that blade is properly mounted. Use a parallel guide.
Blade kicks back when beginning a cut.	Saw blade teeth may be engaged in the material when starting. Blade is not spinning fast enough	Before restarting a saw in the workpiece, center the saw blade in the kerf and check that the saw teeth are not engaged into the material. Allow the saw blade to reach full speed prior to beginning a cut in the material.



# PLUG REPLACEMENT ( ONLY FOR REWIRABLE PLUG OF UK & IRELAND )

If you need to replace the fitted plug then follow the instructions below.

## IMPORTANT

The wires in the mains lead are colored in accordance with the following code:

**BLUE = NEUTRAL**

**Brown = Live**

As the colors of the wires in the mains lead of this appliance may not correspond with the colored markings identifying the terminals in your plug, proceed as follows. The wire which is colored blue must be connected to the terminal which is marked with N. The wire which is colored brown must be connected to the terminal which is marked with L.

**WARNING!** Never connect live or neutral wires to the earth terminal of the plug. Only fit an approved 13ABS1363/A plug and the correct rated fuse.

**NOTE:** If a moulded plug is fitted and has to be removed take great care in disposing of the plug and severed cable, it must be destroyed to prevent engaging into a socket.

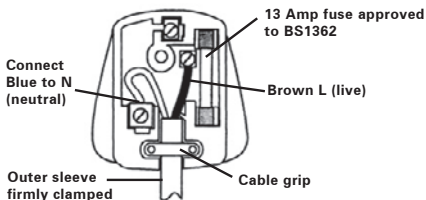

# DECLARATION OF CONFORMITY

We,  
Positec Germany GmbH  
Grüner Weg 10, 50825 Cologne, Germany

Declare that the product  
Description **WORX Electric Circular Saw**  
Type **WX439 (4 - designation of machinery, representative of Saw)**  
Function **Cutting various materials with a rotating toothed blade**

Complies with the following Directives:

**2006/42/EC**

**2011/65/EU**

**2014/30/EU**

Standards conform to

**EN 55014-1**

**EN 55014-2**

**EN 61000-3-2**

**EN 61000-3-3**

**EN 60745-1**

**EN 60745-2-5**

**EN 60745-2-22**

The person authorized to compile the technical file,

**Name Marcel Filz**

**Address Positec Germany GmbH**

**Grüner Weg 10, 50825 Cologne, Germany**

17



2019/02/21  
Allen Ding  
Deputy Chief Engineer, Testing & Certification  
Positec Technology (China) Co., Ltd  
18, Dongwang Road, Suzhou Industrial  
Park, Jiangsu 215123, P. R. China

**WORX**  
**you've got the power**

**[www.worx.com](http://www.worx.com)**

Copyright © 2019, Positec. All Rights Reserved.