

SG60

Escalera de aluminio fija entreplantas y atillo. 60°.
Escada de alumínio fixa mezaninos e sótão. 60°.

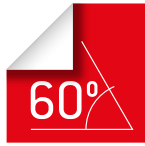

Peldaño antideslizante de 15 cm.
Degrau antiderrapante de 15 cm.



Barandilla de desembarco de 110 cm.
Gradil de desembarque de 110 cm.

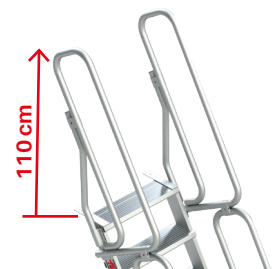

CARACTERÍSTICAS TÉCNICAS

ART.	Nº PELDAÑOS Nº DEGRAUS	PESO (Kg)	A. (cm)	B. (cm)	C. (cm)	G. (cm)
SG60-03	3	11	254	74	60	58
SG60-04	4	12	279	99	60	72
SG60-05	5	16	303	123	60	87
SG60-06	6	18	328	148	60	101
SG60-07	7	20	353	173	60	115
SG60-08	8	24	377	197	60	129
SG60-09	9	26	402	222	60	144
SG60-10	10	28	427	247	60	158
SG60-11	11	30	452	272	60	172
SG60-12	12	34	476	296	60	186
SG60-13	13	36	501	321	60	200
SG60-14	14	38	526	346	60	215
SG60-15	15	40	550	370	60	229
SG60-16	16	44	575	395	60	243

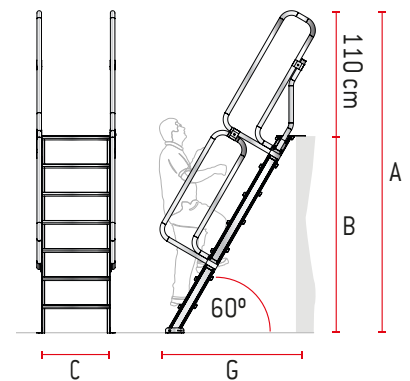

ACCESORIOS OPCIONALES | ACESSÓRIOS OPCIONAIS

ART.	DESCRIPCIÓN / DESCRIÇÃO
SGE-PLA-60	Plataforma de trabajo de 60x100 cm. / Plataforma de trabalho de 60x100 cm.
S-CANCF60	Cancela de seguridad frontal 60 cm. / Porta de segurança frontal 60 cm.

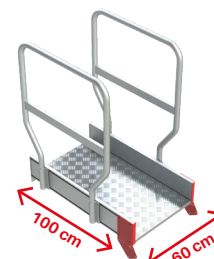

SGE-PLA-60



S-CANCF60