

CODE NO.	THREAD	GRIP RANGE	DRILL	d	D	K	L	I	C	S	GROV	SERR.	Lf	TENSILE(KN)	TORQUE (Nm)
TR04100TSKNI4	M4-P0,7	0,5-3,0	Ø6,0	Ø5,9	Ø6,5	0,50	10,00	4,80	5,20	5,64	24T	30T	5,50	6,80	3,00
TR05115TSKNI4	M5-P0,8	0,5-3,0	Ø7,0	Ø6,9	Ø7,5	0,50	11,50	5,70	5,50	6,64	24T	36T	6,50	10,00	6,00
TR06140TSKNI4	M6-P1,0	0,5-3,0	Ø9,0	Ø8,9	Ø9,5	0,50	14,00	7,60	6,20	8,64	30T	36T	8,20	15,00	10,00
TR08155TSKNI4	M8-P1,25	0,5-3,0	Ø11,0	Ø10,9	Ø11,5	0,50	15,50	9,50	6,70	10,64	36T	36T	10,00	27,00	24,00

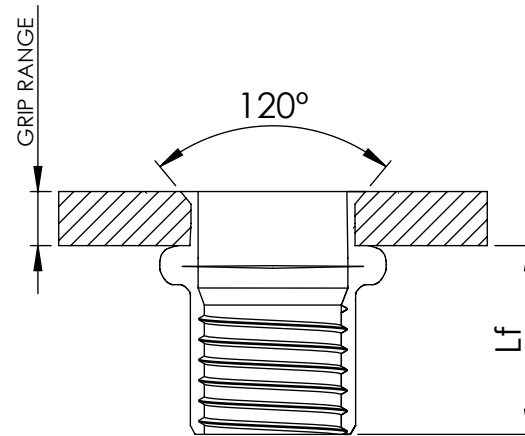
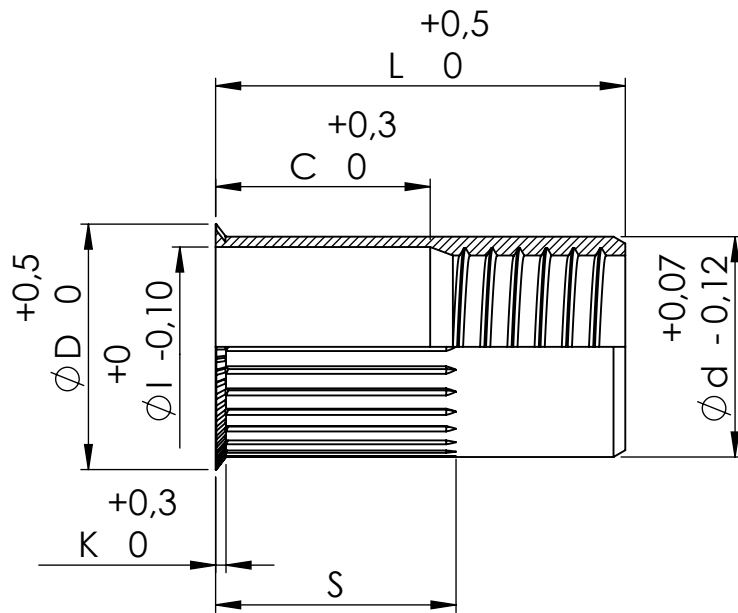

Este plano es propiedad de Remaches Tudela S.L. todos los derechos reservados/ This drawing is property of Remaches Tudela S.L. all rights reserved

DIBUJADO / DRAWN BY FECHA / DATE	J.SANZ 15/11/2021	DENOMINACIÓN / DESCRIPTION	TUERCA REM. INOX A4 C. REDUCIDA RAN. ABIERTA / RIVET NUT REDUCED HEAD KNURLED S.STEEL A4 BODY OPEN-END	ESPECIFICACIONES GENERALES / GENERAL SPECIFICATIONS	
REVISIÓN / REVISION FECHA / DATE	Rev. 0 15/11/2021	MATERIAL	INOX A4 / STAINLESS STEEL A4	TOLERANCIAS / TOLERANCES	
		ACABADO / FINISHED	PASIVADO / BRIGHT	Según plano / According drawing	
		REFERENCIA / REFERENCE	TSKNI4	UNIDADES / UNITS	mm
					A4