

d(mm)	Part No.	L(mm)	Grip Range(mm)		Drill Size (mm)	D(mm)	S(mm)	dm(mm)	P(mm)	Tracción Tensile (N)	Cizalla Shear (N)
			Min	Max		Max	Max	Max	Min		
d=4,0	RL303808	8	1,5	3,5	4,1	8,0	4,0	2,15	27	2200	1600
	RL303895	9,5	3,5	5,0							
	RL303810	10	4,0	5,5							
	RL303811	11	5,0	6,5							
	RL303812	12	6,0	7,5							
	RL3038125	12,5	6,5	8,0							
	RL303813	13	7,0	8,5							
	RL303814	14	7,5	9,5							
	RL3038145	14,5	8,0	10,0							
	RL303815	15	8,5	10,5							
	RL303816	16	9,5	11,5							
	RL303820	20	13,5	15,5							

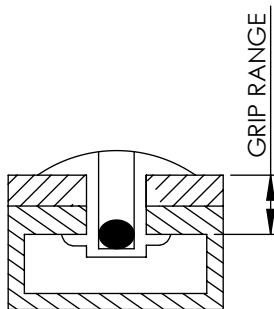
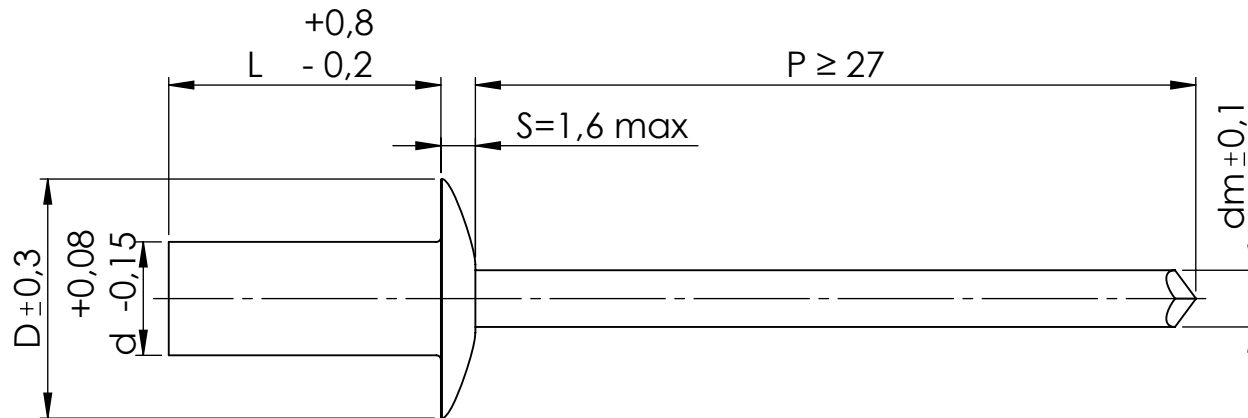

Este plano es propiedad de Remaches Tudela S.L. todos los derechos reservados/ This drawing is the property of Remaches Tudela S.L. all rights reserved											
DIBUJADO / DRAWN BY FECHA / DATE		J.SANZ 15/11/2021		DENOMINACIÓN DESCRIPTION		REMACHE CABEZA ALOMADA LACADO ESTANCO/ DOME HEAD PAINTED SEALED RIVET		ESPECIFICACIONES GENERALES GENERAL SPECIFICATIONS			
REVISIÓN / REVISION FECHA / DATE		Rev. 0 15/11/2021		CUERPO / BODY		CLAVO / MANDREL		TOLERANCIAS Según plano/ TOLERANCES According drawing			
		MATERIAL		ALUMINIO 5% MG ALUMINUM 5% MG		ACERO STEEL		UNIDADES mm			
		ACABADO FINISHED		LACADO PAINTED		LACADO PAINTED		REFERENCIA REFERENCE			
						RL3038					
								A4			