

d(mm)	Part No.	L(mm)	Grip Range(mm)		Drill Size (mm)	D(mm)	S(mm)	dm(mm)	P(mm)	Tracción Tensile (N)	Cizalla Shear (N)
			Min	Max		Max	Max	Max	Min		
d=3,2	RL303206	6	0,5	2,0	3,3	6,1	1,3	1,75	26	1450	1100
	RL303265	6,5	0,5	2,0							
	RL303208	8	2,0	3,5							
	RL303209	9	3,0	4,5							
	RL303295	9,5	3,5	5,0							
	RL303210	10	4,0	5,5							
	RL3032105	10,5	4,5	6,5							
	RL303211	11	5,0	6,5							
	RL303212	12	6,0	7,5							
	RL3032125	12,5	6,5	8,0							
	RL3032127	12,7	6,7	8,2							
	RL303213	13	7,0	8,2							
	RL303214	14	8,0	9,5							

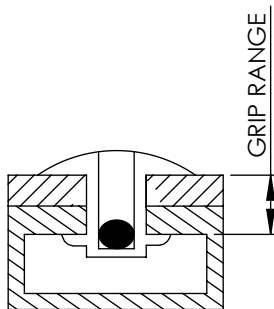
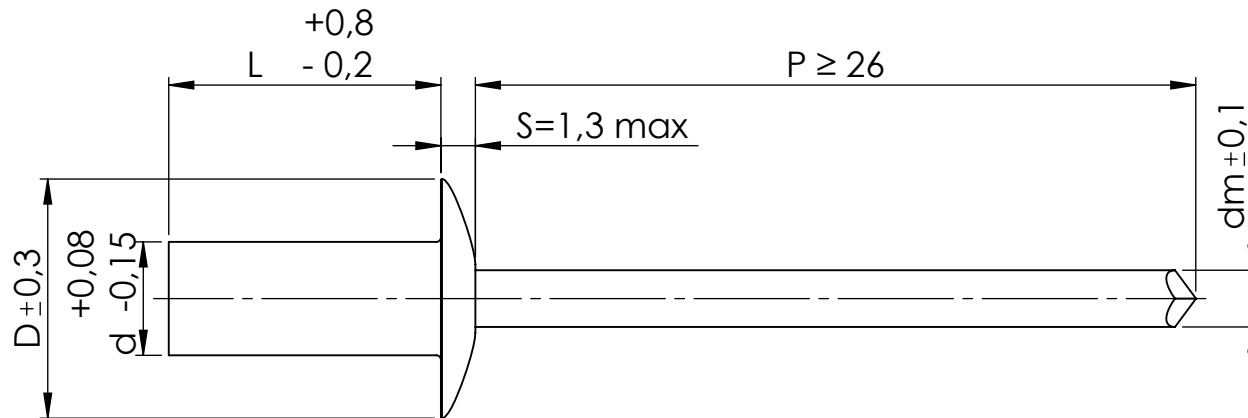

Este plano es propiedad de Remaches Tudela S.L. todos los derechos reservados/ This drawing is the property of Remaches Tudela S.L. all rights reserved											
DIBUJADO / DRAWN BY FECHA / DATE		J.SANZ 15/11/2021		DENOMINACIÓN DESCRIPTION		REMACHE CABEZA ALOMADA LACADO ESTANCO/ DOME HEAD PAINTED SEALED RIVET		ESPECIFICACIONES GENERALES GENERAL SPECIFICATIONS			
REVISIÓN / REVISION FECHA / DATE		Rev. 0 15/11/2021		CUERPO / BODY		CLAVO / MANDREL		TOLERANCIAS Según plano/ TOLERANCES According drawing			
REMACHES TUDELA		MATERIAL		ALUMINIO 5% MG ALUMINUM 5% MG		ACERO STEEL		UNIDADES mm			
		ACABADO FINISHED		LACADO PAINTED		LACADO PAINTED		REFERENCIA REFERENCE			
						RL3032		A4			