

d(mm)	Part No.	L(mm)	Grip Range (mm)		Drill Size (mm)	D(mm) Max	dm(mm) Max	P(mm) Min	Tracción Tensile (N)	Cizalla Shear (N)
			Min	Max						
d=4,8	RL094806	6	2,0	2,5	4,9	9,0	2,63	28	2230	1690
	RL094808	8	2,5	4,0						
	RL094810	10	4,0	6,0						
	RL094812	12	6,0	8,0						
	RL094814	14	8,0	10,0						
	RL094816	16	10,0	12,0						
	RL094818	18	12,0	14,0						
	RL094820	20	14,0	16,0						
	RL094822	22	16,0	18,0						
	RL094825	25	18,0	20,0						
	RL094828	28	20,0	23,0						
	RL094830	30	22,0	25,0						
	RL094835	35	25,0	30,0						

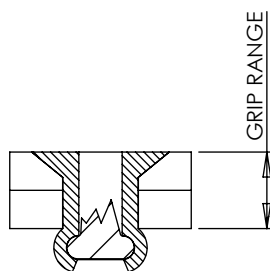
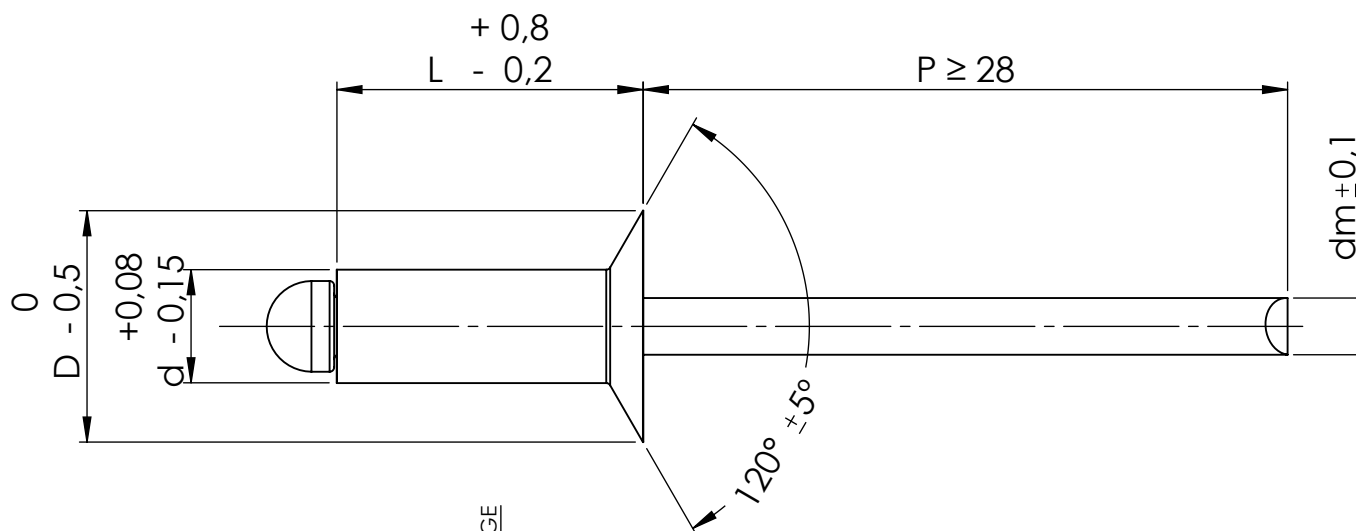

Este plano es propiedad de Remaches Tudela S.L. todos los derechos reservados/ This drawing is the property of Remaches Tudela S.L. all rights reserved					
DIBUJADO / DRAWN BY FECHA / DATE	J.SANZ 15/11/2021	DENOMINACIÓN DESCRIPTION	REMACHE CABEZA AVELLANADA LACADO ESTÁNDAR/ COUNTERSUNK HEAD PAINTED STANDARD RIVET	ESPECIFICACIONES GENERALES GENERAL SPECIFICATIONS	
REVISIÓN / REVISION FECHA / DATE	Rev. 0 15/11/2021	CUERPO / BODY	CLAVO / MANDREL	TOLERANCIAS TOLERANCES	Según plano/ According drawing
	MATERIAL	ALUMINIO 3.5% MG ALUMINUM 3.5% MG	ACERO STEEL	UNIDADES UNITS	mm
	ACABADO FINISHED	LACADO PAINTED	CINCADO ZINC PLATED		
REFERENCIA REFERENCE	RL0948				

A4