

d(mm)	Part No.	L(mm)	Grip Range(mm)		Drill Size (mm)	D(mm)	S(mm)	dm(mm)	P(mm)	Tracción Tensile (N)	Cizalla Shear (N)
			Min	Max		Max	Max	Max	Min		
d=4,8	R0394808	8	2,0	3,5	4,9	9,6	2,0	2,63	28	2800	1950
	R0394811	11	5,0	6,5							
	R03948115	11,5	5,5	7,0							
	R0394814	14	7,0	9,0							
	R0394816	16	9,0	11,0							
	R0394818	18	11,0	13,0							
	R0394819	19	12,0	14,0							
	R0394820	20	13,0	15,0							

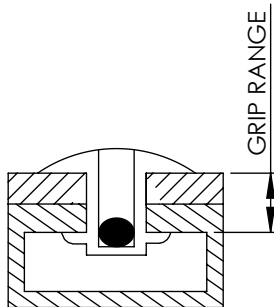
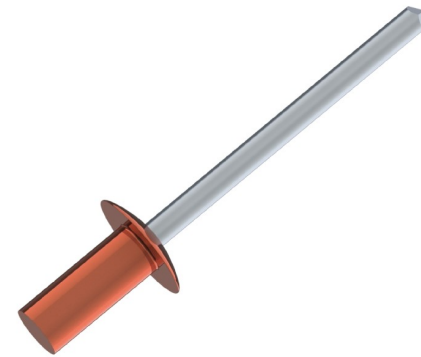
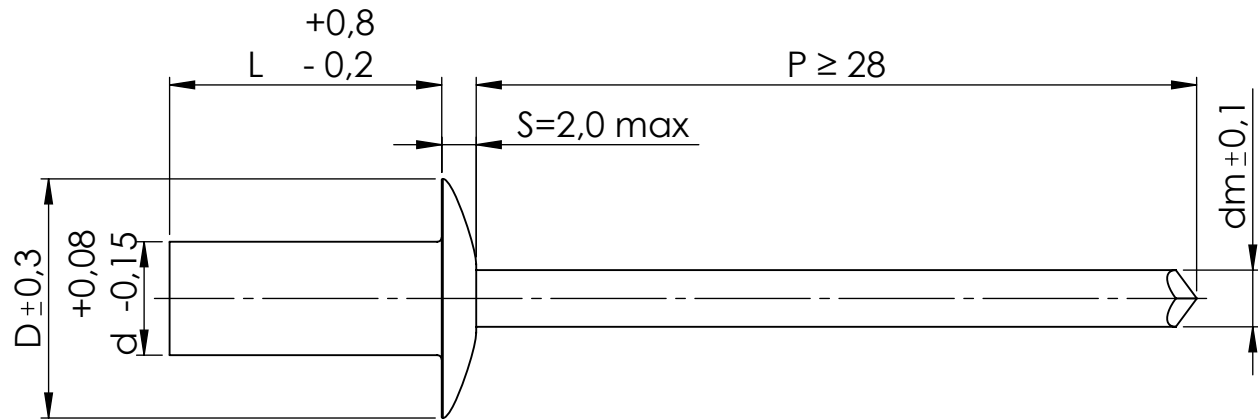

Este plano es propiedad de Remaches Tudela S.L. todos los derechos reservados/ This drawing is the property of Remaches Tudela S.L. all rights reserved											
DIBUJADO / DRAWN BY FECHA / DATE		J.SANZ 15/11/2021		DENOMINACIÓN DESCRIPTION		REMACHE CABEZA ALOMADA ESTANCO/ DOME HEAD SEALED RIVET		ESPECIFICACIONES GENERALES GENERAL SPECIFICATIONS			
REVISIÓN / REVISION FECHA / DATE		Rev. 0 15/11/2021		CUERPO / BODY		CLAVO / MANDREL		TOLERANCIAS Según plano/ TOLERANCES According drawing			
		MATERIAL		COBRE COPPER		ACERO STEEL		UNIDADES mm			
		ACABADO FINISHED		ABRILLANTADO BRIGHTNESS		FOSFATADO PHOSPHATED		REFERENCIA REFERENCE			
						R03948					
								A4			