

d(mm)	Part No.	L(mm)	Grip Range (mm)		Drill Size (mm)	D(mm) Max	dm(mm) Max	P(mm) Min	Tracción Tensile (N)	Cizalla Shear (N)
			Min	Max						
d=4,0	R0123806	6	2,0	3,0	4,1	7,5	2,35	27	2200	1700
	R0123808	8	3,0	5,0						
	R0123810	10	5,0	6,5						
	R0123812	12	6,5	8,0						
	R0123814	14	8,0	10,0						
	R0123816	16	10,0	12,0						
	R0123818	18	12,0	14,0						
	R0123820	20	14,0	16,0						
	R0123825	25	16,0	20,0						
R0123830	30	20,0	25,0							

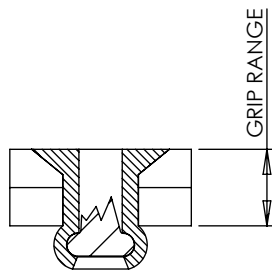
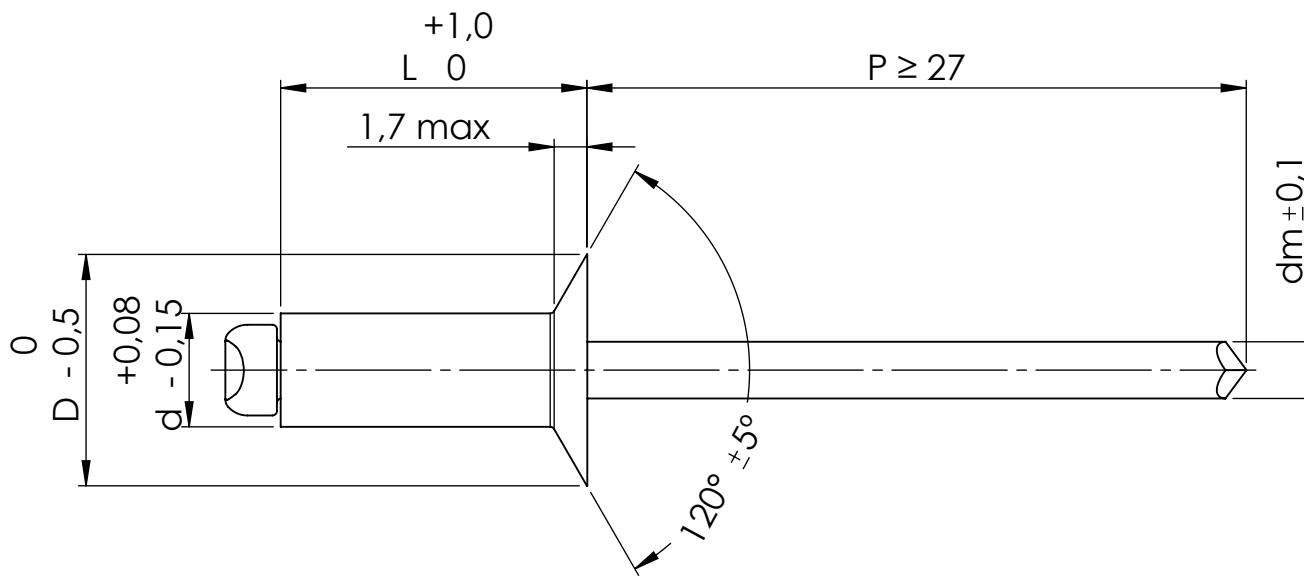

Este plano es propiedad de Remaches Tudela S.L. todos los derechos reservados/ This drawing is the property of Remaches Tudela S.L. all rights reserved					
DIBUJADO / DRAWN BY FECHA / DATE	J.SANZ 15/11/2021	DENOMINACIÓN DESCRIPTION	REMACHE CABEZA AVELLANADA ESTÁNDAR/ COUNTERSUNK HEAD STANDARD RIVET	ESPECIFICACIONES GENERALES GENERAL SPECIFICATIONS	
REVISIÓN / REVISION FECHA / DATE	Rev. 0 15/11/2021	CUERPO / BODY	CLAVO / MANDREL	TOLERANCIAS TOLERANCES	Según plano/ According drawing
<b>REMACHES TUDELA</b>		MATERIAL	ACERO BAJO EN CARBONO LOW CARBON STEEL	ACERO AL CARBONO CARBON STEEL	UNIDADES UNITS
		ACABADO FINISHED	CINCADO ZINC PLATED	CINCADO ZINC PLATED	mm
REFERENCIA REFERENCE	R01238			A4	