

d(mm)	Part No.	L(mm)	Grip Range (mm)		Drill Size (mm)	D(mm) Max	dm(mm) Max	P(mm) Min	Tracción Tensile (N)	Cizalla Shear (N)
			Min	Max						
d=3,2	R0123206	6	1,5	3,0	3,3	6,0	1,92	25	1200	1100
	R0123208	8	3,0	5,0						
	R0123210	10	5,0	6,5						
	R0123212	12	6,5	8,0						
	R0123214	14	8,0	10,0						
	R0123216	16	10,0	12,0						
	R0123218	18	12,0	14,0						
	R0123220	20	14,0	16,0						
R0123225	25	16,0	21,0							

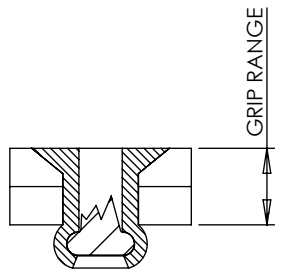
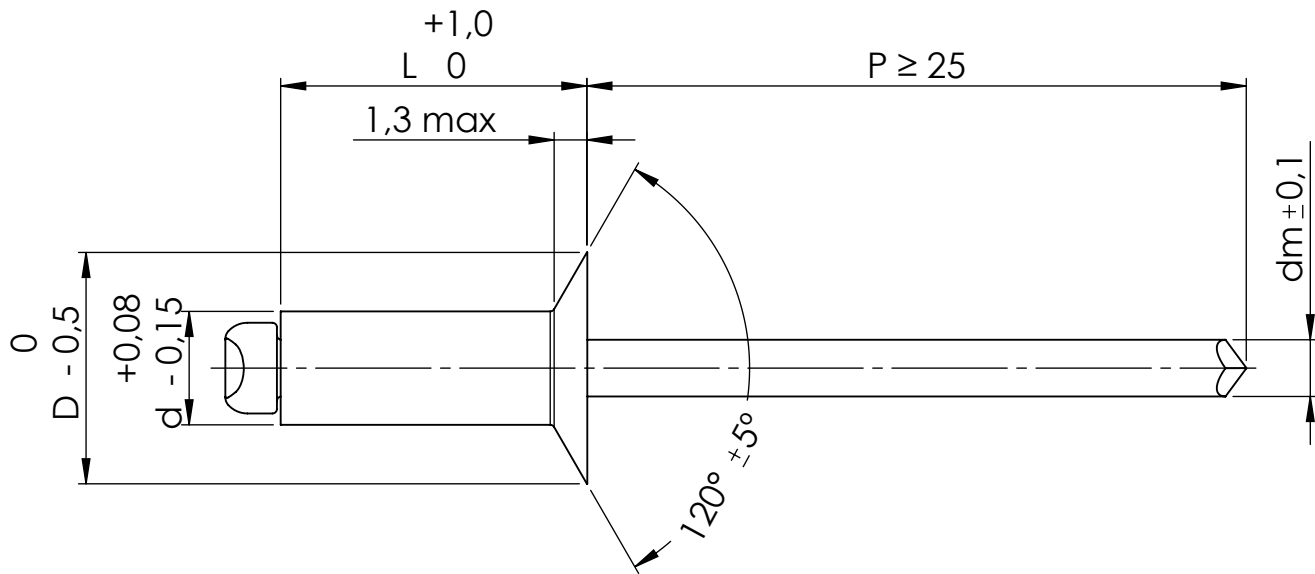

Este plano es propiedad de Remaches Tudela S.L. todos los derechos reservados/ This drawing is the property of Remaches Tudela S.L. all rights reserved					
DIBUJADO / DRAWN BY FECHA / DATE	J.SANZ 15/11/2021	DENOMINACIÓN DESCRIPTION	REMACHE CABEZA AVELLANADA ESTÁNDAR/ COUNTERSUNK HEAD STANDARD RIVET	ESPECIFICACIONES GENERALES GENERAL SPECIFICATIONS	
REVISIÓN / REVISION FECHA / DATE	Rev. 0 15/11/2021	CUERPO / BODY	CLAVO / MANDREL	TOLERANCIAS TOLERANCES	Según plano/ According drawing
REMACHES TUDELA		MATERIAL	ACERO BAJO EN CARBONO LOW CARBON STEEL	ACERO AL CARBONO CARBON STEEL	UNIDADES UNITS
		ACABADO FINISHED	CINCADO ZINC PLATED	CINCADO ZINC PLATED	mm
REFERENCIA REFERENCE	R01232			A4	