

CODE NO.	THREAD	GRIP RANGE	DRILL	d	D	K	L	I	C	S	GROV	SERR.	Lf	TENSILE(KN)	TORQUE (Nm)
TR04100LFKNI4	M4-P0,7	0,5-3,0	Ø6,0	Ø5,9	Ø8,5	1,00	10,00	4,80	6,50	5,64	24T	30T	6,00	6,80	3,00
TR05120LFKNI4	M5-P0,8	0,5-3,0	Ø7,0	Ø6,9	Ø9,5	1,00	12,00	5,70	6,50	6,64	24T	36T	7,50	10,00	6,00
TR06145LFKNI4	M6-P1,0	0,5-3,0	Ø9,0	Ø8,9	Ø12,5	1,50	14,50	7,60	7,20	8,64	30T	36T	10,20	15,00	10,00
TR08160LFKNI4	M8-P1,25	0,5-3,0	Ø11,0	Ø10,9	Ø15,5	1,50	16,00	9,50	7,70	10,64	36T	36T	10,80	27,00	24,00

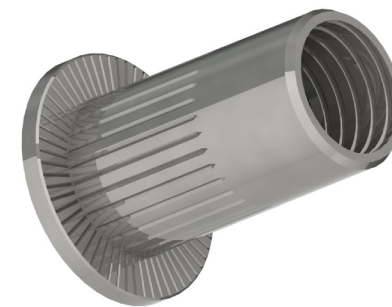
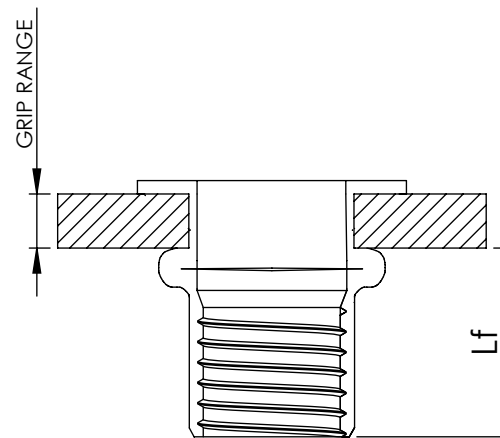
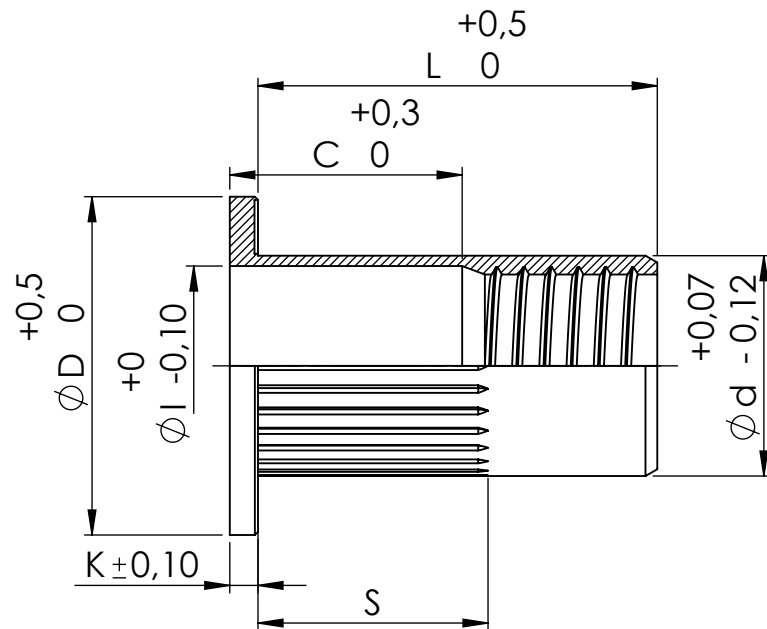

Este plano es propiedad de Remaches Tudela S.L. todos los derechos reservados/ This drawing is property of Remaches Tudela S.L. all rights reserved

DIBUJADO / DRAWN BY FECHA / DATE	J.SANZ 15/11/2021	DENOMINACIÓN / DESCRIPTION	TUERCA REM. INOX A4 C.ANCHA RAN.ABIERTA / RIVET NUT FLAT HEAD KNURLED S.STEEL A4 BODY OPEN-END	ESPECIFICACIONES GENERALES / GENERAL SPECIFICATIONS
REVISIÓN / REVISION FECHA / DATE	Rev. 0 15/11/2021	MATERIAL	INOX A4 / STAINLESS STEEL A4	TOLERANCIAS / TOLERANCES Según plano / According drawing
		ACABADO / FINISHED	PASIVADO / BRIGHT	UNIDADES / UNITS mm
		REFERENCIA / REFERENCE	LFKNI4	A4